

EXPERIMENTS ON THE PFLÜGER COLUMN: FLUTTER FROM FRICTION

Davide Bigoni¹, Oleg Kirillov², Diego Misseroni¹, Giovanni Noselli³, Mirko Tommasini¹

¹DICAM, University of Trento, Trento, Italy

²Russian Academy of Sciences, Steklov Mathematical Institute, Moscow, Russia

³SISSA, International School for Advanced Studies, Trieste, Italy

Flutter and divergence instabilities are theoretically and experimentally analyzed in elastic structures with internal and external damping. Despite of the fact that only the former (and not the latter) was believed to be a destabilizing effect, it is theoretically demonstrated that the external damping plays a role similar to internal damping, so that both yield a pronounced destabilization paradox (in the Ziegler sense).

This finding and other features of the Beck and Pflüger columns are substantiated by an experimental campaign in which the follower forces are obtained via dry friction with a newly designed experimental apparatus.

Keyword: Pflüger column, Beck column, Ziegler destabilization paradox, damping, follower force

1. INTRODUCTION

Flutter and divergence instabilities may occur in elastic structures subject to tangential follower loads and well-known examples are the Ziegler double pendulum and the Beck¹⁾ and Pflüger²⁾ columns. A key point in these mechanical frameworks is the realization of the follower force, which has been long debated and often considered of impossible practical realization, as discussed in detail by Elishakoff³⁾.

The controversy about the realization of the force was definitively solved by Bigoni and Noselli⁴⁾, who showed how to realize a follower tangential force in the Ziegler pendulum via Coulomb friction. Their idea, sketched in Fig. 1, was to provide the follower force through a wheel of negligible mass mounted at the end of the Ziegler double pendulum and constrained to slide against a frictional plane.

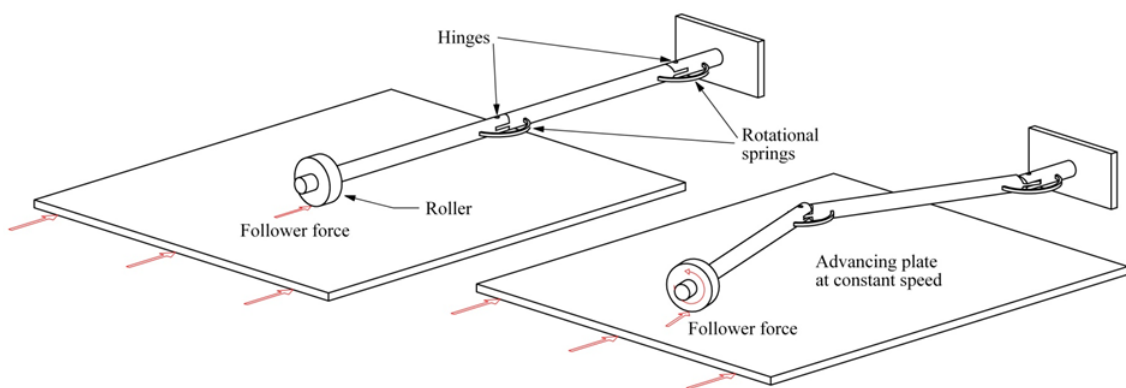

Figure 1: Sketch of the experiment set-up to realize a follower tangential force in the Ziegler double pendulum (figure adapted from [4]).

2. ZIEGLER'S PARADOX DUE TO INTERNAL AND EXTERNAL DAMPING

The linearized equations of motion for the Ziegler pendulum, made up of two rigid bars of length l , loaded by a follower force P , when both the internal and external damping are present, have the form⁵⁾

$$\mathbf{M}\ddot{\mathbf{x}} + c_i \mathbf{D}_i \dot{\mathbf{x}} + c_e \mathbf{D}_e \dot{\mathbf{x}} + \mathbf{K}\mathbf{x} = 0, \quad (1)$$

where a superimposed dot denotes time derivative and c_i and c_e are the coefficients of internal and external damping, respectively, in front of the corresponding matrices \mathbf{D}_i , \mathbf{D}_e

$$\mathbf{D}_i = \begin{pmatrix} 2 & -1 \\ -1 & 1 \end{pmatrix}, \quad \mathbf{D}_e = \frac{l^3}{6} \begin{pmatrix} 8 & 3 \\ 3 & 2 \end{pmatrix}, \quad (2)$$

and \mathbf{M} and \mathbf{K} are respectively the mass and the stiffness matrices, defined as

$$\mathbf{M} = \begin{pmatrix} m_1 l^2 + m_2 l^2 & m_2 l^2 \\ m_2 l^2 & m_2 l^2 \end{pmatrix}, \quad \mathbf{K} = \begin{pmatrix} -Pl + 2k & Pl - k \\ -k & l \end{pmatrix}, \quad (3)$$

in which k is the elastic stiffness of both viscoelastic springs acting at the hinges. Assuming a time-harmonic solution to the Eq. (1) in the form $\mathbf{x} = \mathbf{u} e^{\sigma t}$ and introducing the non-dimensional parameters

$$\lambda = \frac{\sigma l}{k} \sqrt{km_2}, \quad E = c_e \frac{l^2}{\sqrt{km_2}}, \quad B = \frac{c_i}{l\sqrt{km_2}}, \quad F = \frac{Pl}{k}, \quad \mu = \frac{m_2}{m_1}, \quad (4)$$

an eigenvalue problem is obtained, which eigenvalues λ are the roots of the characteristic polynomial.

In the undamped case, when $B = 0$ and $E = 0$, the pendulum is stable, if $0 \leq F \leq F_u^-$, unstable by flutter, if $F_u^- \leq F \leq F_u^+$, and unstable by divergence, if $F > F_u^+$, where

$$F_u^\pm(\mu) = \frac{5}{2} + \frac{1}{2\mu} \pm \frac{1}{\sqrt{\mu}} \quad (5)$$

In the case when only internal damping is present ($E = 0$) the Routh-Hurwitz criterion yields the flutter threshold as

$$F_i(\mu, B) = \frac{25\mu^2 + 6\mu + 1}{4\mu(5\mu + 1)} + \frac{1}{2}B^2. \quad (6)$$

The limit for vanishing internal damping is

$$\lim_{B \rightarrow 0} F_i(\mu, B) = F_i^0(\mu) = \frac{25\mu^2 + 6\mu + 1}{4\mu(5\mu + 1)}. \quad (7)$$

Let us evaluate the difference between the flutter onset in the absence of damping and that in the limit of vanishing internal damping: $\Delta_i = F_u^- - F_i^0$. We find that for all non-negative values of μ

$$\Delta_i = \frac{1}{4} \frac{\mu(5\sqrt{\mu} - 2)^2 + (2\sqrt{\mu} - 1)^2 + 6\mu}{\mu(5\mu + 1)} > 0. \quad (8)$$

Hence, the critical flutter load in the limit of vanishing internal damping is smaller than that of the undamped system for all physically possible mass distributions⁵. For instance, at $\mu = 0.5$ corresponding to the original Ziegler problem⁴, the drop in the critical load is

$$\Delta_i = \frac{57}{28} - \sqrt{2} \approx 0.622. \quad (9)$$

The discrepancy between the flutter onset in the ideal (undamped system) and in the dissipative system with the vanishing internal damping is known as the Ziegler destabilization paradox. Since its discovery, it is widely believed that such a dissipation-induced destabilization is a privilege of internal damping only⁵.

In a route similar to the above, by employing the Routh-Hurwitz criterion, the critical flutter load of the Ziegler pendulum with the external damping $F_e^0(\mu, E)$ can be found and its limit calculated when $E \rightarrow 0$, which provides the result

$$F_e^0(\mu) = \frac{122\mu^2 - 19\mu + 5 - (2\mu + 1)\sqrt{112\mu^2 + (13\mu - 5)^2}}{5\mu(8\mu - 1)}. \quad (10)$$

Calculating the discrepancy $\Delta_e = F_u^- - F_e^0$, we establish that at $\mu \geq 0$

$$\Delta_e = \frac{2(2\mu + 1)\sqrt{112\mu^2 + (13\mu - 5)^2} - (11\mu - 5)(4\mu - 3)}{10\mu(8\mu - 1)} - \frac{1}{\sqrt{\mu}} \geq 0. \quad (11)$$

For instance, $\Delta_e = (\sqrt{281} - 11)/20 \approx 0.288$ in the limit $\mu \rightarrow \infty$, corresponding to $m_2 = 0$, $m_1 \neq 1$. Consequently, the external damping yields destabilization and a finite drop in the critical flutter load for all mass distributions except a finite number of mass distributions at which $\Delta_e = 0$. Therefore, both internal and external damping leads to the qualitatively the same Ziegler's destabilization paradox for almost all physically plausible mass distributions, in contrast to the common belief. The same result is valid for the continuous analogue of the Ziegler pendulum – the Pflüger column loaded by the follower force⁸⁾.

2. THE EXPERIMENTAL REALIZATION OF THE BECK COLUMN

The experimental realization by Bigoni and Noselli was found unsuitable for the analysis of the Beck and the Pflüger columns, because if the ellipse of inertia of the cross-section of the rod to be tested is elongated, lateral torsional buckling occurs and if the ellipse of inertia of the cross-section of the rod is a circle, flexure involves large deformation, too large to produce the force necessary to flutter. Therefore, a new apparatus has been designed, following the scheme reported in Fig. 2 and realized.

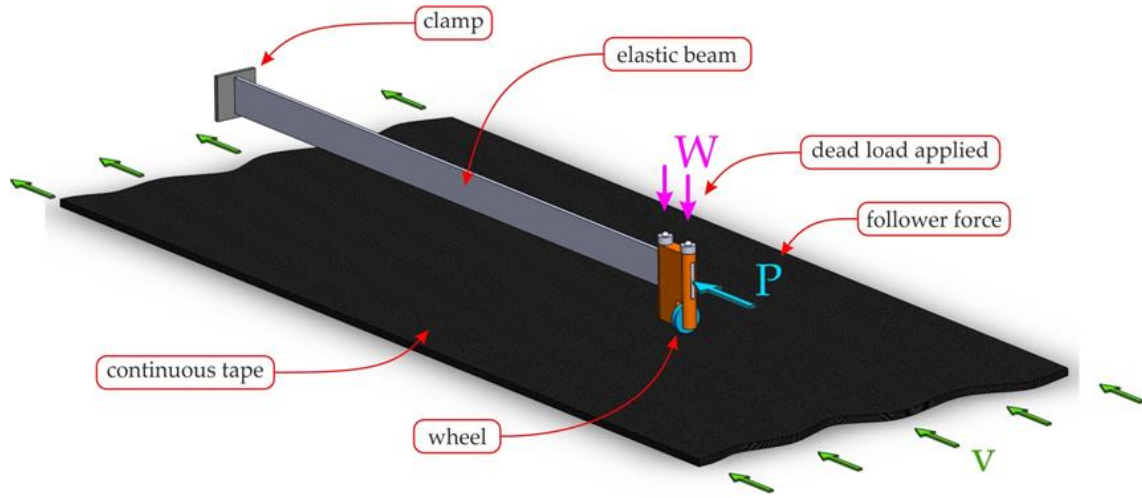

Figure 2: Sketch of the experimental setup to realize a follower tangential force in the Pflüger column.

The elastic structure is installed over a continuous tape that can move with a fixed velocity v . The force P is transmitted to the free end of the beam with a dead load W . The friction of the wheel with the tape generates the tangential follower force, as in the Ziegler model.

The new experimental setup allows the first realization of follower tangential forces on elastic structures and allows a systematic investigation of flutter, divergence, and dissipation-induced instabilities^{6,7)} changing the dead weight, the mass ratio or the velocity of the plane. In these experiments, internal and external damping (respectively the viscosity of the material and the air drag for instance) play a chief role, so that the effects associated to these two types of damping have been thoroughly investigated. From theoretical

point of view it is shown that external damping plays a destabilizing role qualitatively similar to internal damping⁸⁾, a feature previously not believed⁵⁾, and which is now also experimentally confirmed.

In Fig. 3 are shown the discrete system (Ziegler pendulum) and the continuous one (Pflüger column) mounted on the new testing machine realized.

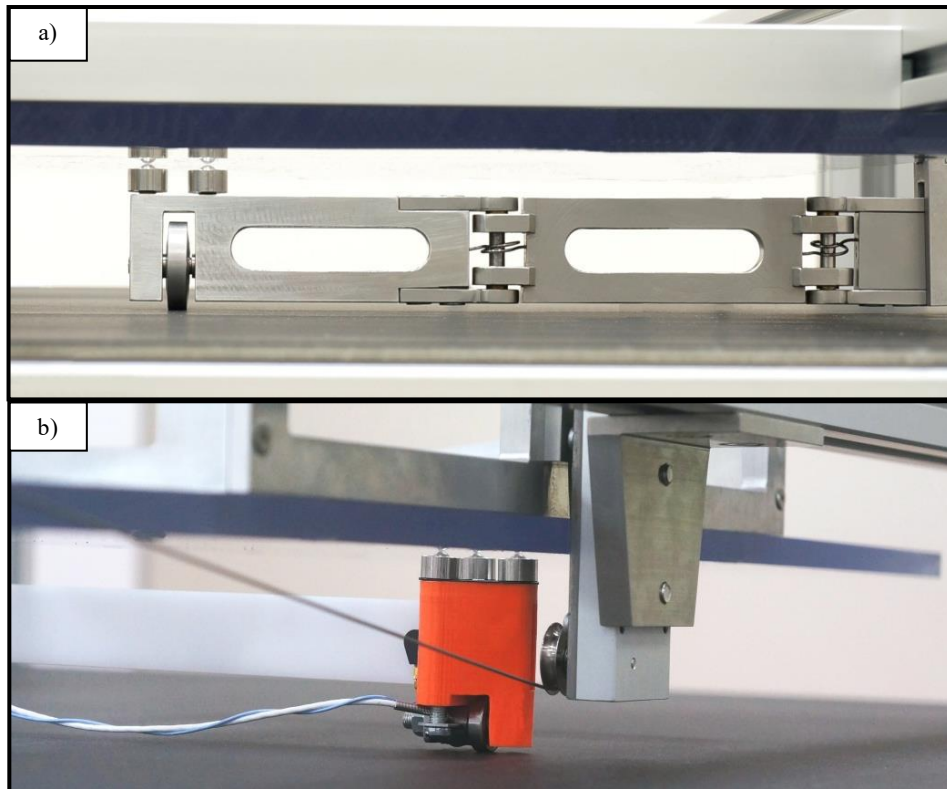

Figure 3: a) Ziegler column mounted on the experimental device, b) detail of the free end of the Pflüger column realized in the laboratory.

The Fig. 4 is a frame taken from a test with the new device. The beam shows clearly a flutter instability for a certain amount of load, and the amplitude of the motion depends on the velocity of the plane under the structure.



Figure 4: Deformed shape of the Pflüger column in flutter condition.

4. CONCLUSION

A theoretical framework and an experimental setup have been proposed for the investigation of flutter and divergence instabilities in elastic continuous structures, in the presence of internal and external damping. Results confirm recent a classical theoretical findings that were never experimentally verified and pave the way to the realization of self-oscillating mechanisms of completely new design.

ACKNOWLEDGEMENT

The authors gratefully acknowledge financial support from the ERC Advanced Grant ‘Instabilities and nonlocal multiscale modelling of materials’ FP7-PEOPLE-IDEAS-ERC-2013-AdG (2014-2019).

REFERENCES

- 1) Beck, M. Die Knicklast des einseitig eingespannten, tangential gedrückten Stabes. *Z. angew. Math. Phys.* 3:225, 1952.
- 2) Pflüger, A. Zur Stabilität des tangential gedrückten Stabes. *Z. angew. Math. Mech.* 35:191, 1955.
- 3) Elishakoff, I. Controversy associated with the so-called “follower force”: critical overview. *Appl. Mech. Rev.* 58:117-142, 2005.
- 4) Bigoni, D., Noselli, G. Experimental evidence of flutter and divergence instabilities induced by dry friction. *J. Mech. Phys. Solids* 59:2208–2226, 2011.
- 5) Panovko, Ya.G., Sorokin, S.V. Quasi-stability of viscoelastic systems with tracking forces. *Mech. Solids*. 22: 128-132, 1987.
- 6) Krechetnikov, R. Marsden, J.E. Dissipation-induced instabilities in finite dimensions. *Rev. Modern. Phys.* 79:519-553, 2007.
- 7) Kirillov, O.N. *Nonconservative stability problems of modern physics*. De Gruyter, Berlin/ Boston, 2013.
- 8) Tommasini, M., Kirillov, O., Misseroni, D., Bigoni, D. The destabilizing effect of external damping: Singular flutter boundary for the Pflüger column with vanishing external. *Submitted*.